

Enabling Digital Engineering with Semantic Blueprints

Alan Moore

Architecture Modeling Specialist at MathWorks

Digital Engineering Main Principles

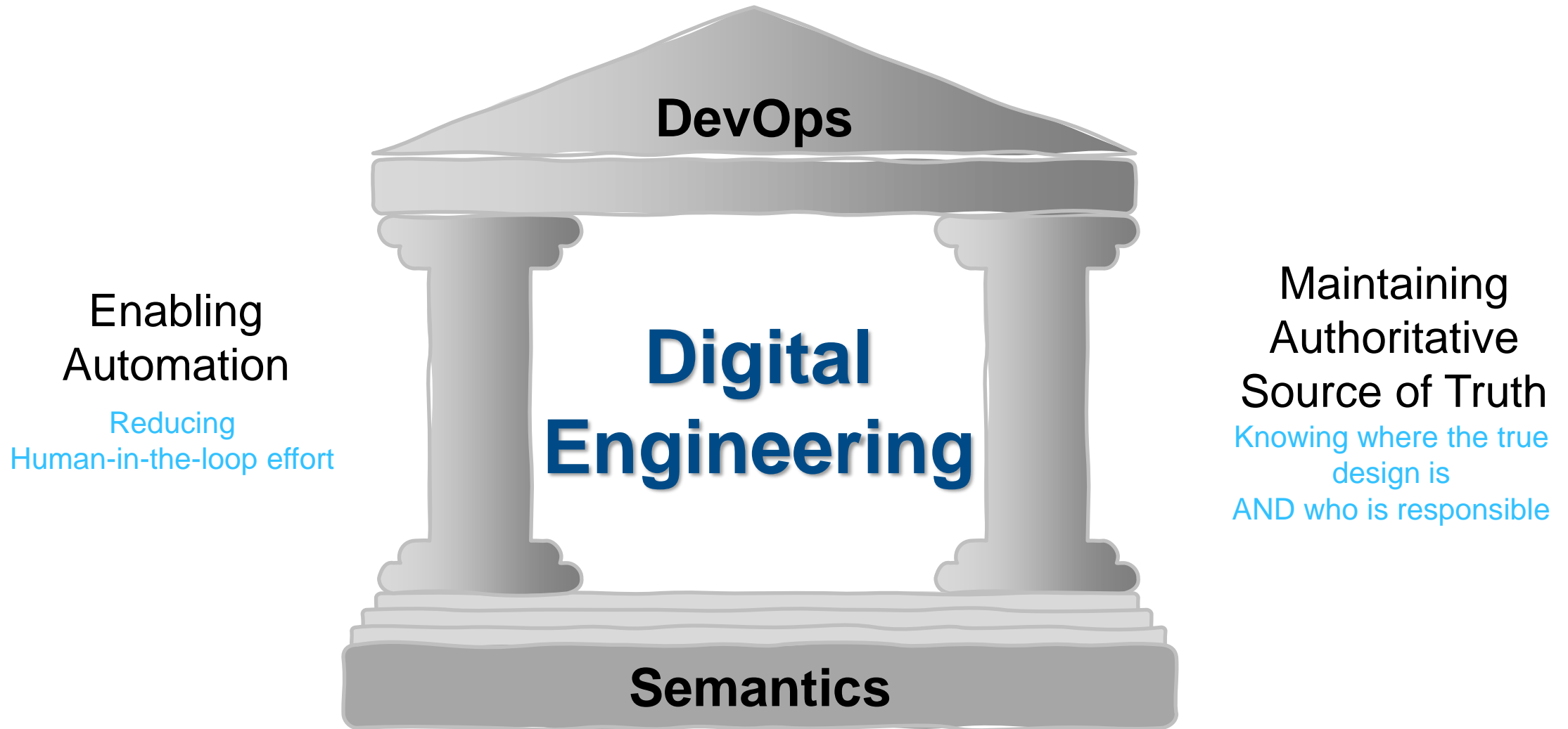

DevOps – An Agile and Iterative Development Approach

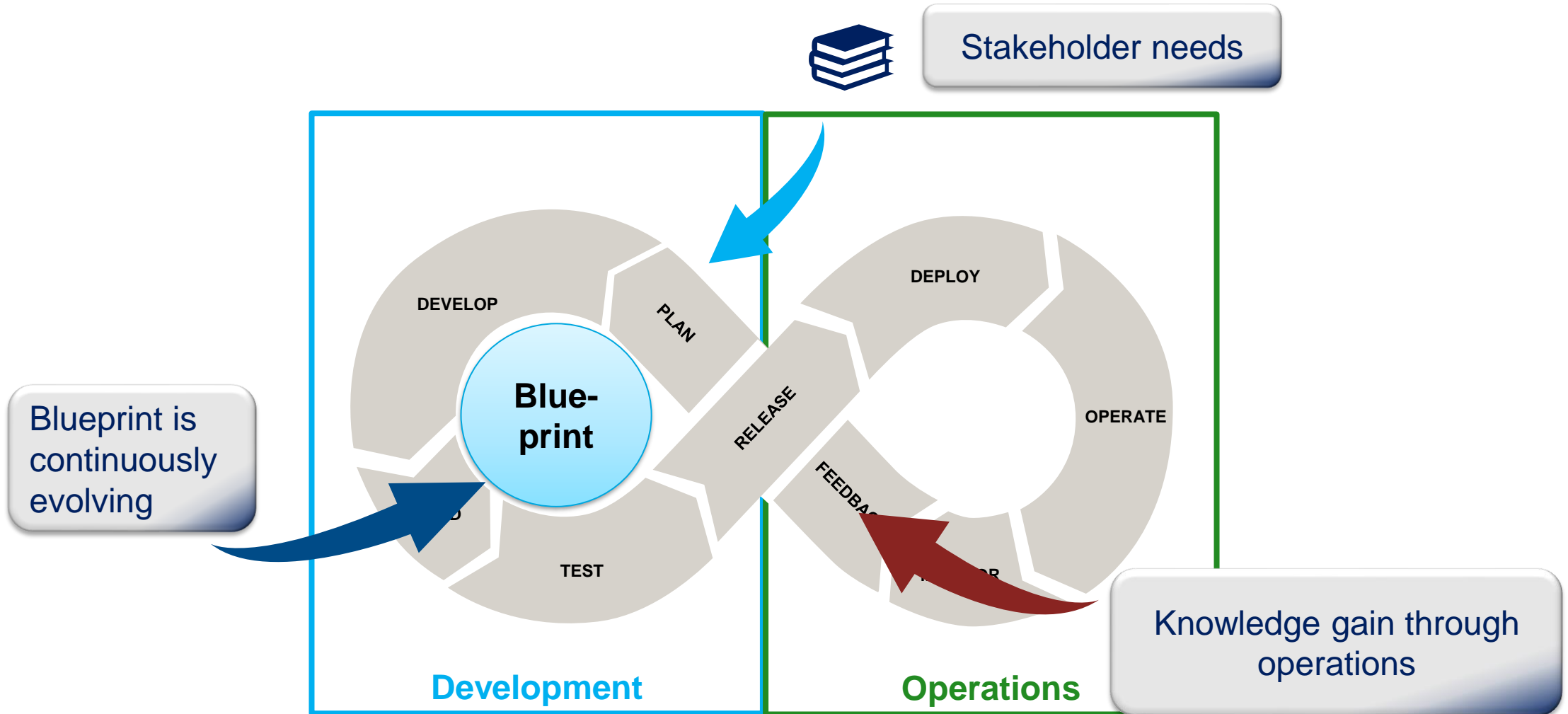

Engineering Ecosystem

Goal: Develop blueprint of the system

Blueprint “ all of the information that is needed to build or make something.”

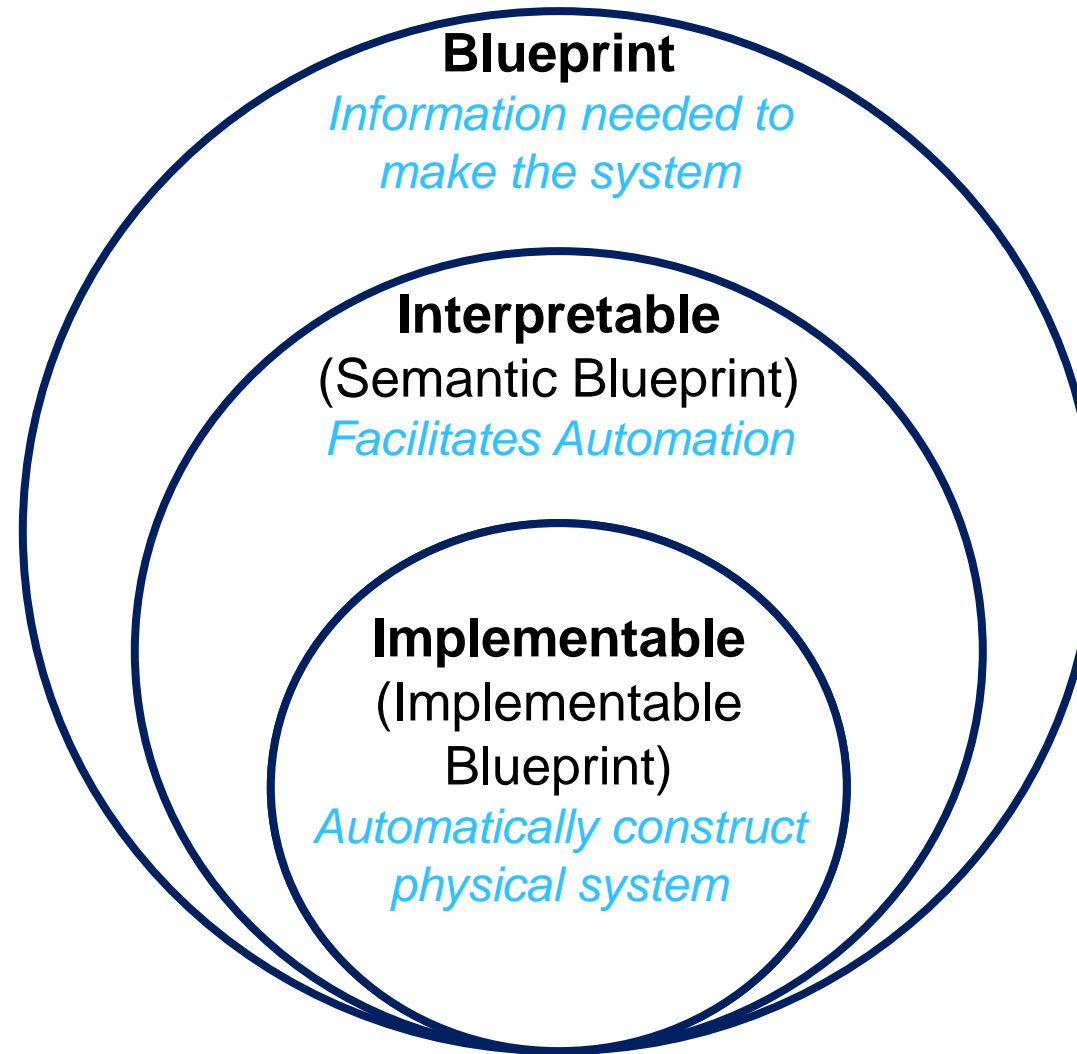

System Design From Document to (Semantic) Blueprint

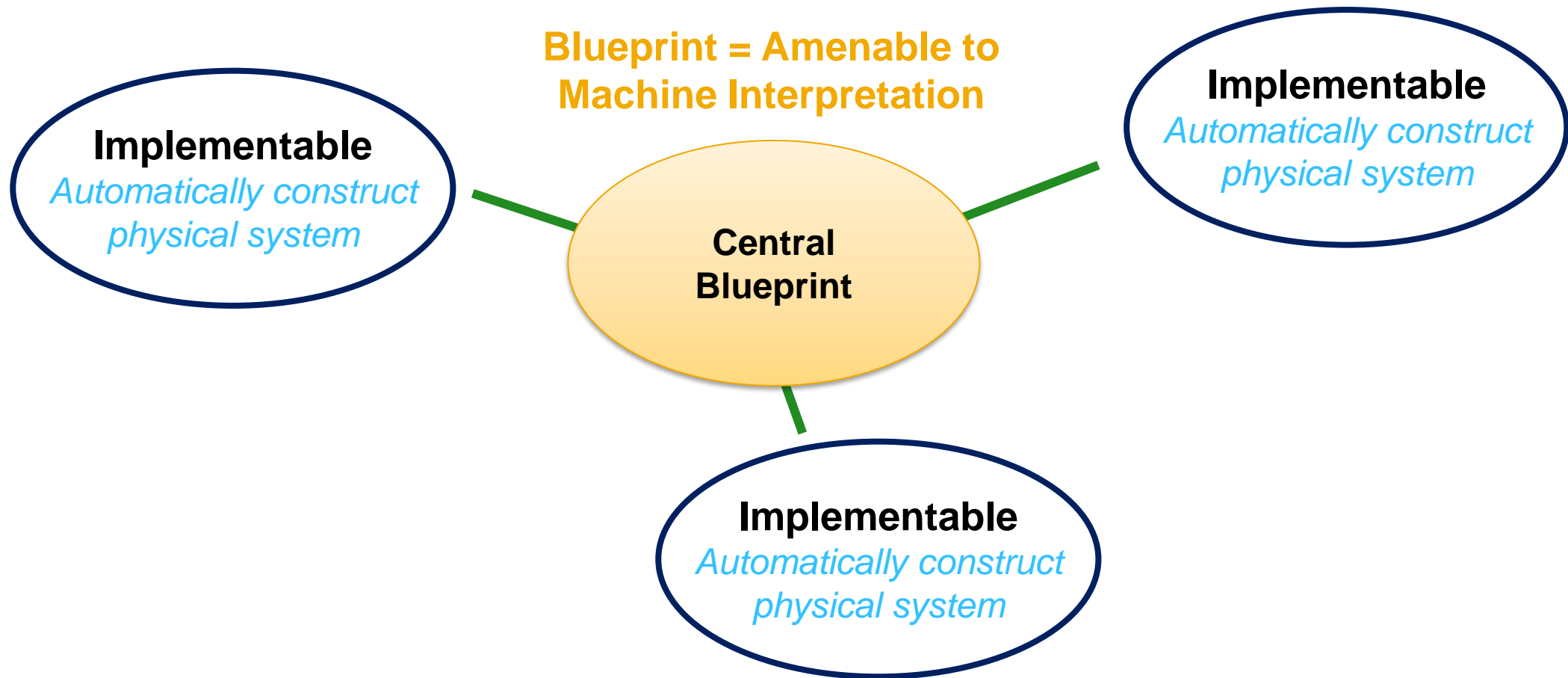

SysML: a language for expressing system blueprints

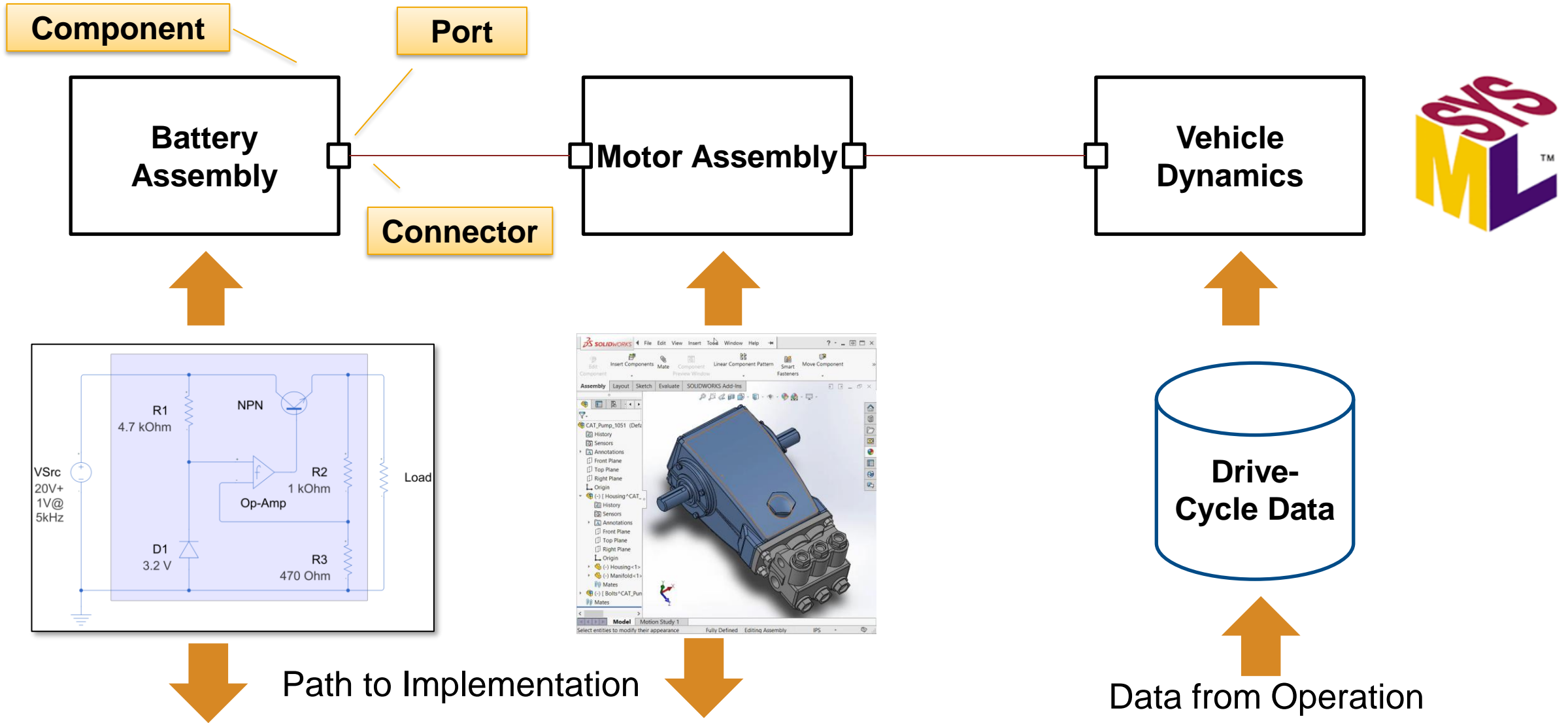

Semantics

Model - "a system that shares observable properties with a system of interest."

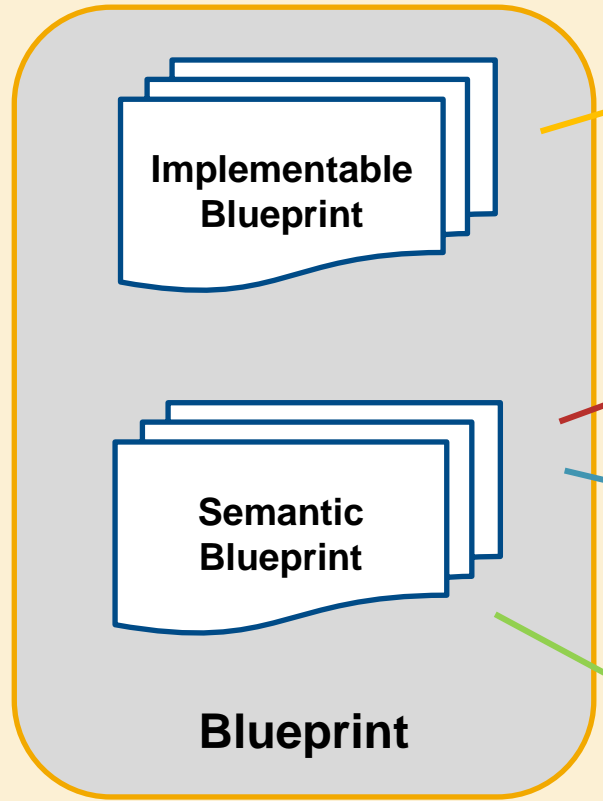

Syntax



Implementation

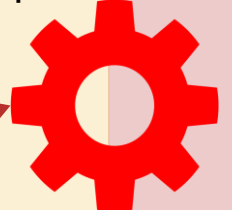

Parametric Analysis



Steady State Analysis



Dynamic Analysis

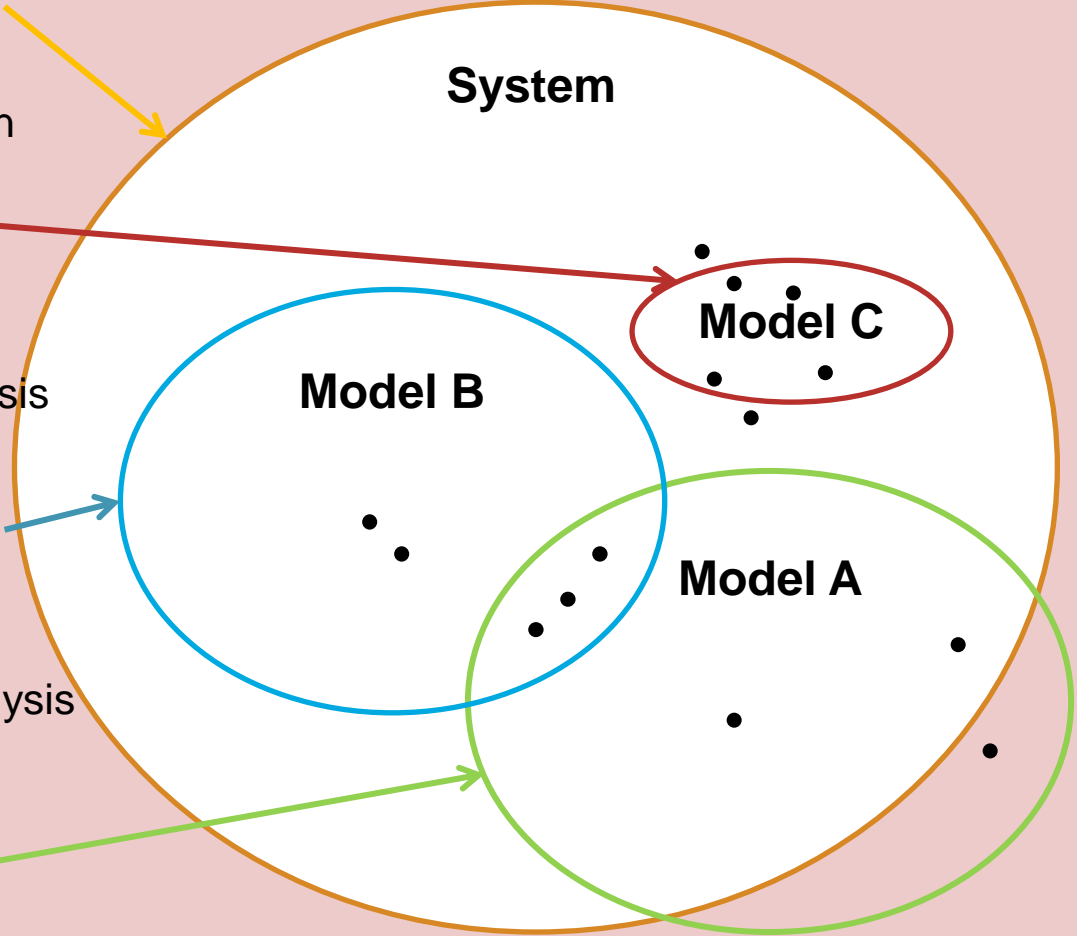

Semantics

Model Produced from a Blueprint with Dynamic Semantics



BEV Main Script

Open

Set-Up Script

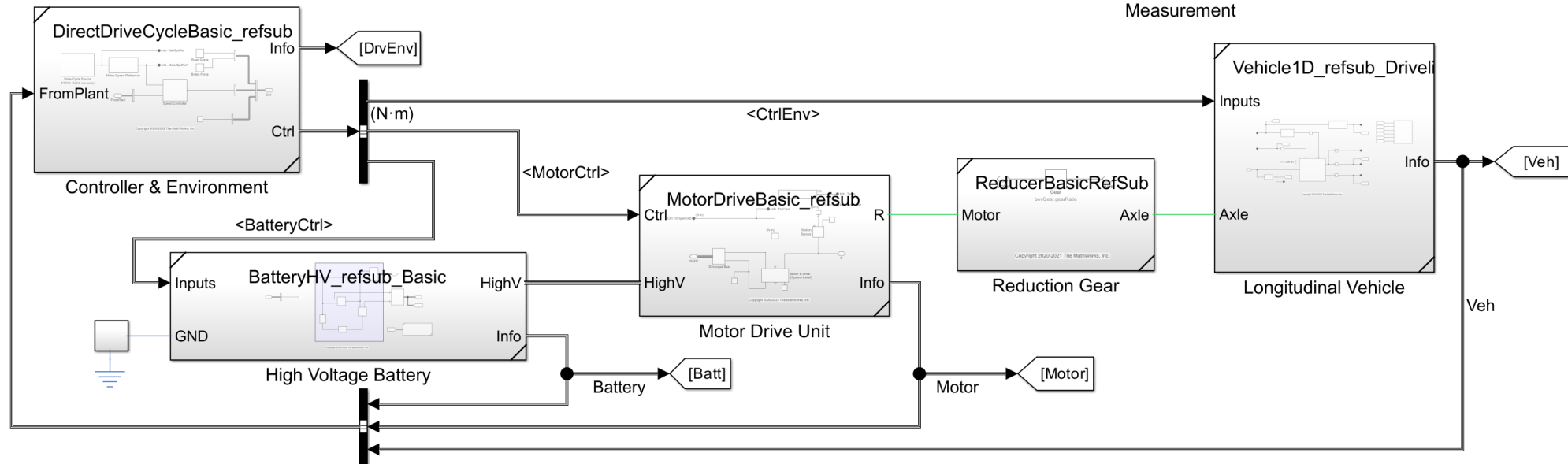
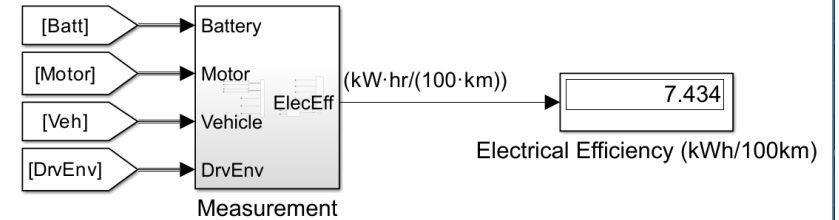

Static Model Built from a Blueprint

Instances	Endurance	Mass	DischargeR:Voltage	Capacity	PowerDraw	Diameter	Efficiency
EnduranceModel_Onboard	3.78963830691	138		2500	146.4519711522		
Airframe		46					
Battery		5	0	3.7	2500	0	
CameraModule		47		0	46		
Camera		25		0	20		
PowerSwitch		2		0	1		
VideoProcessor		20		0	25		
Harness		2					
IMU		10		0	10		
LeftFrontMotor		5		0	17.61299278804	50	0.67
LeftRearMotor		5		0	17.61299278804	50	0.67
OnboardProcessor		8		0	20		
RightFrontMotor		5		0	17.61299278804	50	0.67
RightRearMotor		5		0	17.61299278804	50	0.67

INSTANCE PROPERTIES

ComponentInstance: EnduranceModel_Onboard

Property	Value	Units	Edit
QuadcopterPhysicalProperties.AirVehicle			
Endurance	3.79	min	
QuadcopterPhysicalProperties.BasicComponent			
Mass	138	g	
QuadcopterPhysicalProperties.ElectricalComponent			
Capacity	2,500	mAh	
PowerDraw	146.452	W	
QuadcopterPhysicalProperties.HW_Implementation			

Digital Engineering – Authoritative Source of Truth

- Semantic blueprints are the key to automation
- System blueprints are required to integrate often siloed implementable blueprints
- System blueprints with semantics support the production of system models which are essential to the design process

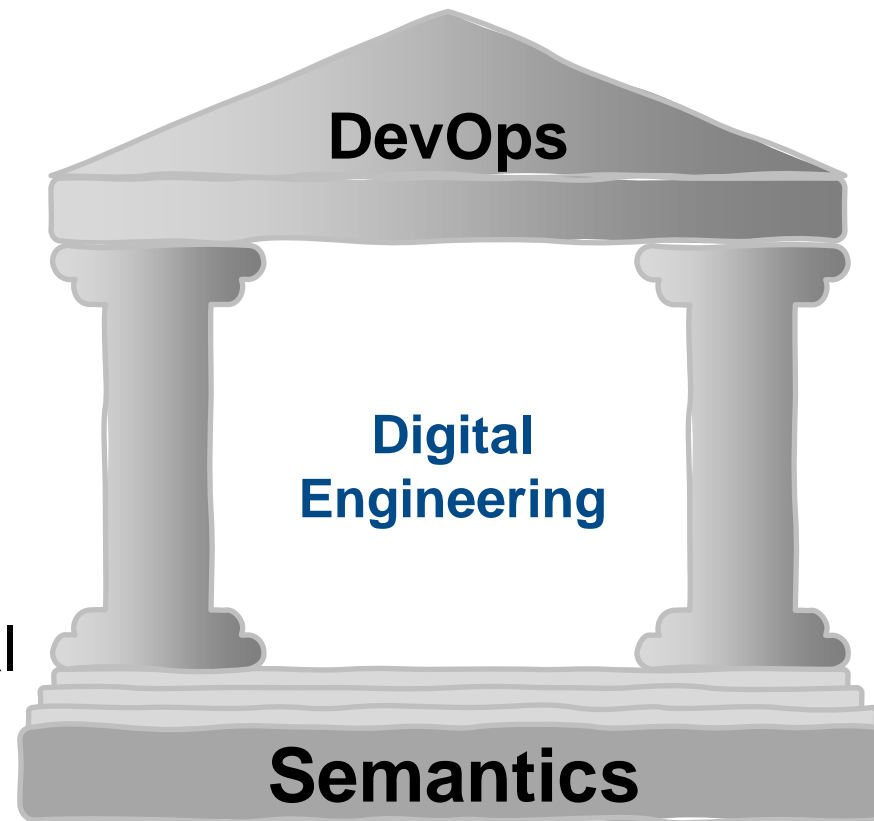

Maintaining
Authoritative
Source of Truth
Knowing where the true
design is
AND who is responsible

Ambiguous Authority

Changes made here

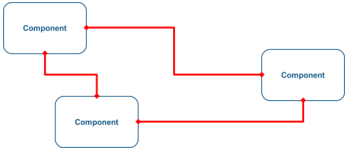

Design

blueprint

Automatic



Source is here



Embedded Software

blueprint

Automatic

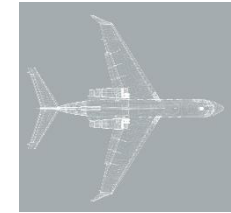

Implementation

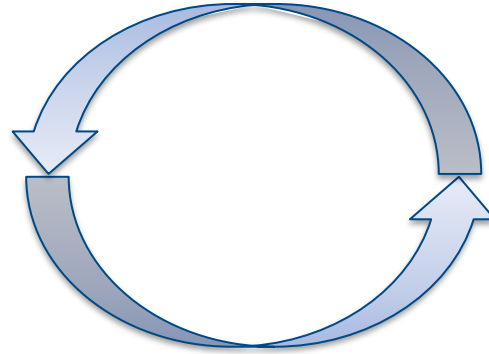

Which one is the truth ?

Make the design the
Implementable Blueprint

Implementable Software Blueprint

- Component/port/connector paradigm maps well to modern software/firmware frameworks
- Choice of language for component behavior

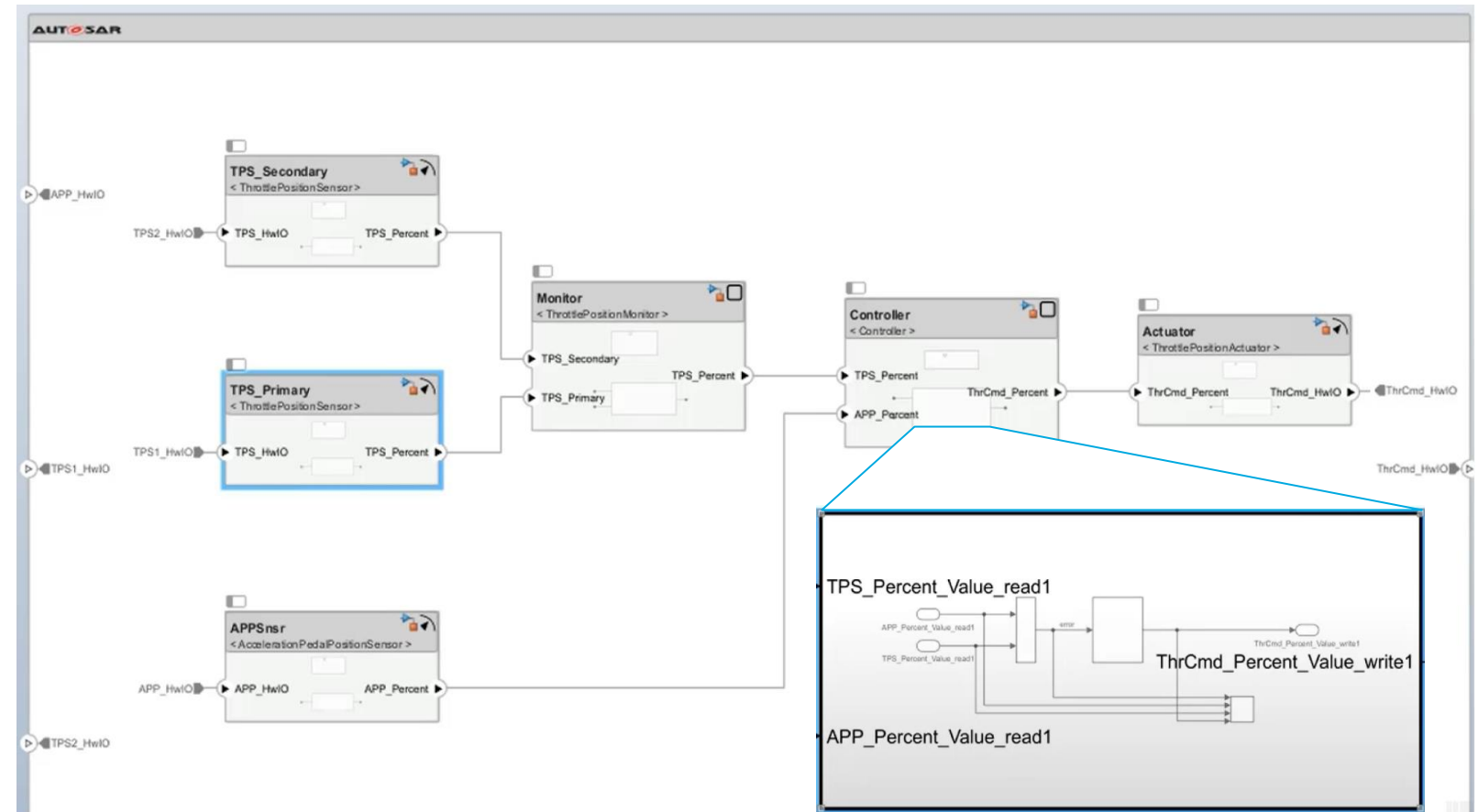

Stakeholder Authority



Stakeholders

System

Subsystem

How do you maintain the compliance to stakeholders' requirements when modified by the Authority at lower level ?

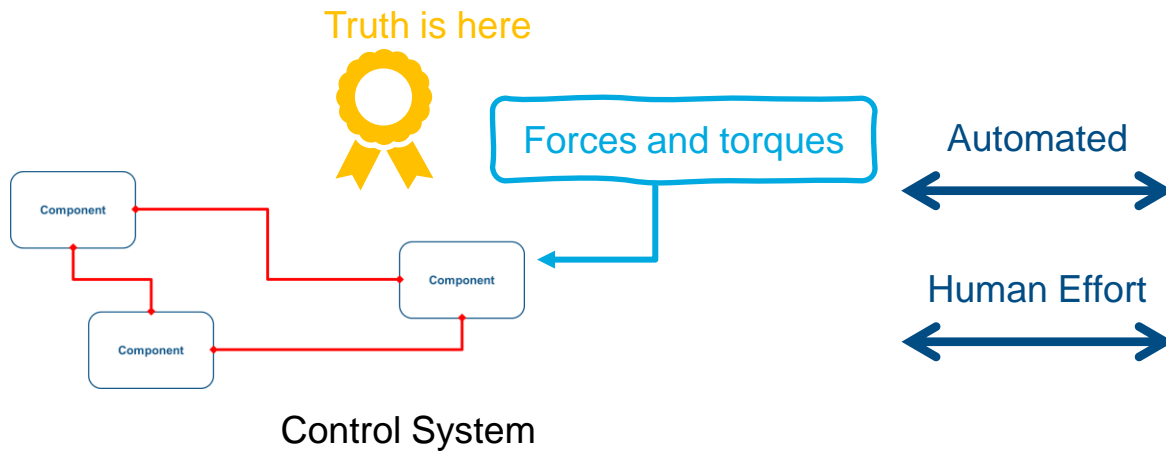

Authority of Source

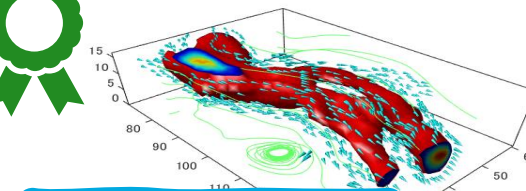

Forces and torques

Truth is here



Aerodynamics

Formalizing Authority Using Constraints



Thermodynamic Authority

Realization

Requirement: 4

Details

▼ Properties

Type: Functional

Index: 1.3

Custom ID: 4

Summary: Activate Heat Pump

Description Rationale

The pump shall activate when the temperature difference is greater than or equal to 2 degrees for more than 2 seconds and stay active for at least 2 seconds.

Constraint

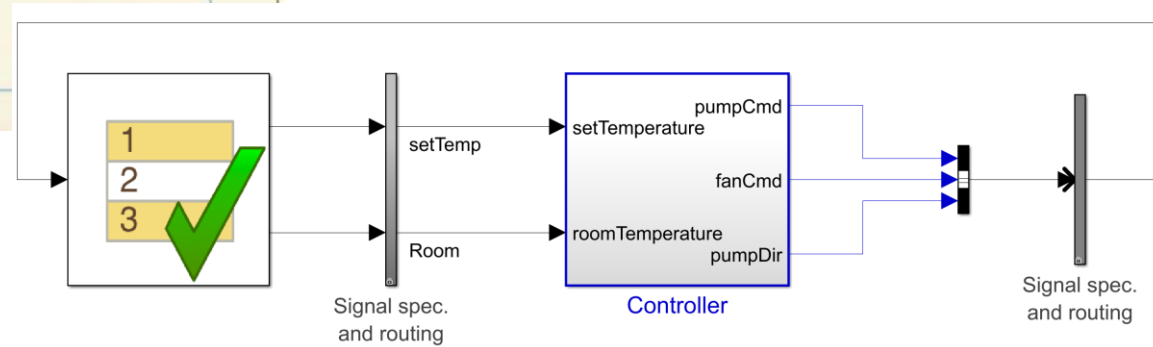
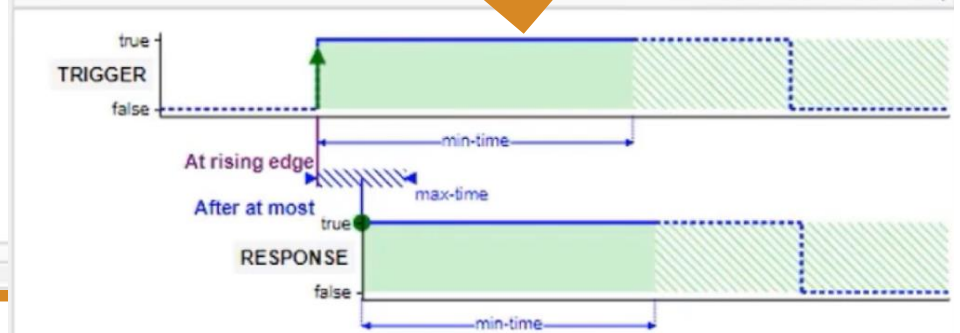
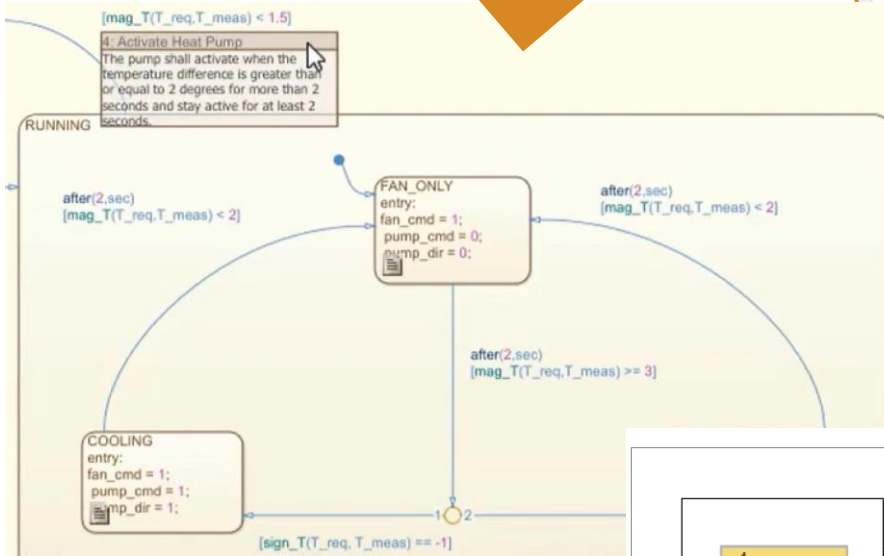

- SYMBOLS
- roomTemperature
 - setTemperature
 - pumpCmd
 - threshold
 - fanCmd

Experiment

DevOps – Artefact Criticality

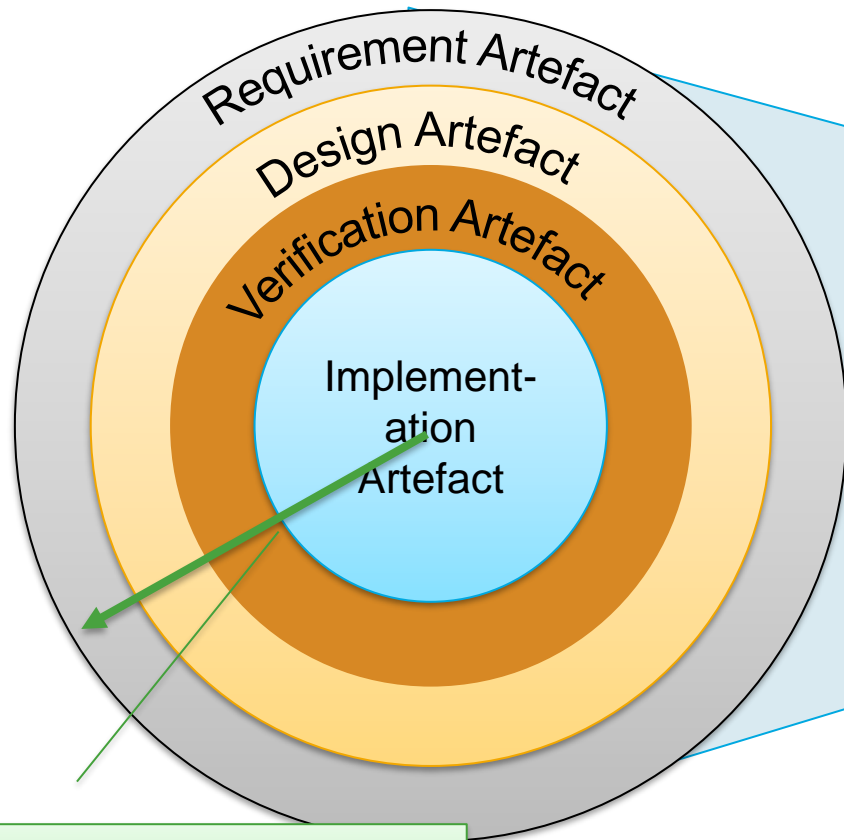

Decreasing Criticality

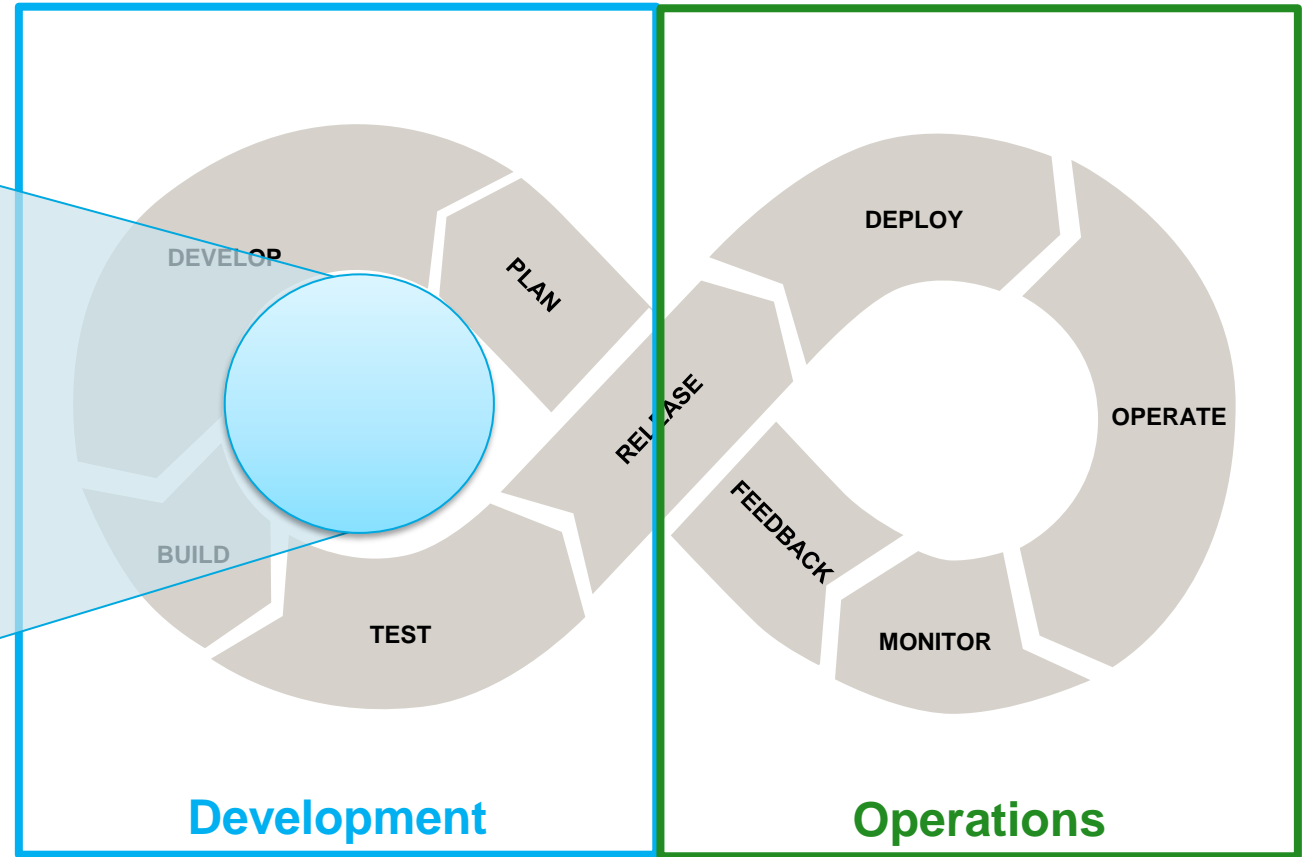

Conclusion

- DevOps and agile workflows are fast becoming the accepted wisdom for software development
 - It seems inevitable and fitting that these approaches emerge in system development workflows
- The principles of digital engineering are a good fit with agile system development workflows
 - Automation enables rapid development iterations
 - Authoritative source of truth identifies the data around which the infinity loop revolves
- Semantic blueprints give meaning to authoritative source of truth and are essential to automation

